

**POWER PURCHASE AGREEMENT FOR ROOFTOP SOLAR PV PLANTS  
WITH NET METERING ARRANGEMENT**

This Power Purchase agreement is entered into at (place) ***Imphal*** on this .....day of .....  
....., **2024** between Manipur State Power Distribution Company Limited (MSPDCL), a Government of Manipur undertaking, a Company formed and incorporated in India under the Companies Act-1956, with its registered office located ***at Secured Building, 3<sup>rd</sup> Floor, New Directorate Building, near 2<sup>nd</sup> MR Gate, Imphal – Dimapur, Imphal***, Manipur State, represented by ..... hereinafter referred to as the “MSPDCL / Licensee”, (which expression shall, unless repugnant to the context or meaning thereof, include its successors and permitted assigns) as party of the **first part**.

**AND**

Manipur Renewable Energy Development Agency (MANIREDA) having its registered Office at ***Secured Building, 2<sup>nd</sup> Floor, South Block, New Directorate Building, near 2<sup>nd</sup> MR Gate, Imphal – Dimapur, Imphal*** through its authorized representatives ..... hereinafter referred to as “MANIREDA” (which expression shall, unless repugnant to the context or meaning thereof, include its successors and permitted assigns) as party of the **Second part**

**AND**

*Shri/Smt*.....the consumer of MSPDCL residing ..... hereinafter referred to as the "Seller" (which expression shall, unless repugnant to the context or meaning thereof, include its successors and permitted assigns) as party of the **Third part**.

**Whereas,**

**a.** The Licensee agrees to provide grid connectivity to the eligible consumer for injection of the electricity generated from his Solar Rooftop capacity \_\_\_\_\_ ***kW*** into the power system of Licensee as per the terms & conditions of this agreement and the Joint Electricity Regulatory Commission for Manipur and Mizoram, JERC (M&M) (Metering for Grid Connected Renewable Energy) Regulations, 2016

**b.** The Seller intends to install a SRTPV system of \_\_\_\_\_ ***kWp*** capacity on the existing roof top of the premises situated at .....  
.....and bearing **Meter No** .....  
**Service Connection** **No** ..... in the same premises under .....Sub-Division of MSPDCL.

**c.** The Seller intends to sell the energy generated from the Solar Roof Top Photo Voltaic (SRTPV) system to MSPDCL on net metering concept, from the date of commissioning of the SRTPV system.

**d.** MSPDCL intends to purchase the energy generated by such SRTPV system, on net metering concept, at the tariff determined by the JERC (M&M) for Rooftop Solar Plants in Manipur.

Now therefore, in consideration of the foregoing promises, the parties hereto, intending to be legally bound hereby agree as under:

**1. Eligibility**

Eligibility for net metering has been specified in the relevant regulations of the JERC for Manipur and Mizoram. Eligible seller has to meet the standards and conditions for being integrated into grid/distribution system.

**2. Technical and Interconnection Requirements**

2.1 The eligible seller agrees that his Renewable Energy Plant and metering system shall

conform to the standards and requirements specified in JERC for Manipur and Mizoram (Metering for Grid Connected Renewable Energy) Regulations, 2016 and in the following Regulations and codes as amended from time to time:

- (i) Central Electricity Authority (Technical Standards for Connectivity of the Distributed Generation Resources) Regulations, 2013as amended from time to time.
- (ii) Central Electricity Authority (Installation and Operation of Meters) Regulation 2006, as amended from time to time.
- (iii) JERC for Manipur and Mizoram (Electricity Supply Code) Regulations, 2013, as amended from time to time.

2.2 The seller agrees that he has installed or shall install, prior to connection of Renewable Energy Plant to Licensee's distribution system, an isolation device (both automatic and inbuilt within inverter and external manual relays) and agrees for the Licensee to have access to and operation of this, if required and for repair & maintenance of the distribution system.

2.3 The seller agrees that in case of a power outage on Licensee system, Renewable Energy Plant shall disconnect/isolate automatically and his plant shall not inject power into Licensee's distribution system.

2.4 All the equipment connected to distribution systems shall be compliant with relevant International (IEEE/IEC) or Indian standards (BIS) and installations of electrical equipment must comply with Central Electricity Authority (Measures relating to Safety and Electric Supply) Regulations, 2010 as amended from time.

Any equipment failure in and during the operation shall not come under the purview of MSPDCL.

2.5 The seller agrees that licensee shall specify the interface/interconnection point and metering point. The meter should be sealed jointly after due verification of the meter readings.

2.6 The seller and licensee agree to comply with the relevant CEA and JERC for Manipur & Mizoram Regulations in respect of operation and maintenance of the plant, drawing and diagrams, site responsibility schedule, harmonics, synchronization, voltage, frequency, flicker etc.

2.7 Due to Licensee's obligation to maintain a safe and reliable distribution system, Eligible Seller agrees that if it is determined by the Licensee that eligible seller's Renewable Energy Plant either

causes damage to and/or produces adverse effects affecting other Seller or Licensee's assets, eligible consumer shall have to disconnect Renewable Energy Plant immediately from the distribution system upon direction from the Licensee and correct the problem at his own expense prior to re connection.

- 2.8 The Seller in respect of net metering shall be solely responsible for any accident to human being/animals what so ever (fatal/non-fatal) that may occur due to back feeding from the solar plant when the grid supply is off. The licensee reserves the right to disconnect the Seller's installation at any time in the event of such exigencies to prevent accident or damage to life and property.

### **3. Clearances and Approvals**

The Seller shall obtain MSPDCL's approvals and clearances before connecting the SRTPV system to the distribution system.

### **4. Access and Disconnection**

- 4.1 MSPDCL shall have access to metering equipment and disconnecting device of SRTPV system, both automatic and manual, at all times.
- 4.2 In emergency or outage situation, where there is no access to a disconnecting device either automatic or manual, the MSPDCL shall have the right to disconnect services to the premise of the seller.

### **5. Liabilities**

The Seller shall be solely responsible for availing any fiscal or other incentive provided by the State/ Central government, at his own expenses.

### **6. Commercial Settlement**

- 6.1 All the commercial settlement under this agreement shall follow the Joint Electricity Regulatory Commission for Manipur and Mizoram (Metering for Grid Connected Renewable Energy) Regulations, 2016 and subsequent amendments thereof.

#### **6.2 Tariff:**

- a. The consumer shall be paid for net energy credits which remain unadjusted at the end of the settlement period at the rate of Average Power purchase Cost (APPC) of the Distribution Licensee for the respective year on provisional basis. Subsequently after true up of the power purchase cost of the Distribution Licensee, by the Commission, adjustment amount between provisional rate and trued up rate of average power purchase cost shall be credited/debited to the account of consumer in the next billing cycle after issuance of the true up order of the relevant year by Commission. This

tariff shall be revised and fixed by the Commission from time to time depending on prevailing circumstances.

Provided also that at the beginning of each settlement period, cumulative carried over solar electricity injected shall be reset to zero.

Provided that the solar tariff will be implemented on the levellised tariff (feed-in – tariff) determined by the Commission particularly w.r.t the Solar Rooftop Phase-II scheme.

- b. The Seller shall pay the Electricity tax and other statutory levies, pertaining to SRTPV generation, as may be levied from time to time.
- c. The seller shall not have any claim for compensation, if the Solar power generated by his SRTPV system could not be absorbed by the distribution system due to failure of power supply in the grid/ distribution system for the reasons, such as line clear, load shedding and line faults, whatsoever.

## **7. Metering:**

7.1.1 The net-metering arrangement shall be as per the Regulations for installation & operation of meters for renewable energy systems specified in these regulations.

7.1.2 The schematic arrangement for interconnection of Rooftop Solar Power Plant with the Distribution Licensee's grid is shown at (**Annexure-I**). There shall be two meters. The metering arrangement shall be as per (**Annexure-II**).

7.1.3 The bi-directional (net meter) shall be installed at the interconnection point of the eligible Consumer with the network of the distribution licensee:

Provided that for the existing consumers, the consumer meter shall be replaced with the bi-directional/ net meter:

Provided further that consumers having ABT compliant meters shall not be required to install additional net meter.

7.2 Renewable energy meter shall be installed at the renewable facility after the inverter to measure the renewable energy generation.

7.3 All the meters shall have the facility for downloading meter readings using Meter Reading Instrument (MRI). Check meters shall be mandatory for rooftop solar systems having capacity more than 250 kW. For installations size of less than and equal to 250 kW, the solar check meters would be optional:

Provided that the cost of new/additional meter (s) and necessary accessories shall be borne by the renewable energy generator and installed & owned by the distribution licensee without bearing rental charge:

Provided, if bills are prepared on the basis of MRI downloads or if meter reading is taken on the basis of remote meter reading and the eligible consumer wishes to have a record of the reading taken, he shall be allowed so by the licensee.

- 7.4 The meters installed shall be jointly inspected and sealed on behalf of both the parties and shall be interfered / tested or checked only in the presence of the representatives of the eligible consumer or third party owner and distribution licensee or as per the supply code specified by the Commission:

Provided that the eligible Seller or third party owner shall follow the metering specifications and provisions for placement of meter as developed by the distribution licensee as per the JERC for Manipur and Mizoram (Electricity Supply Code) Regulations, 2013 as amended from time to time:

Provided further that in case the eligible Seller is under the ambit of time of day (TOD) tariff, meters compliant of recording time of day consumption/generation shall be employed.

- 7.5 The meter readings taken by the distribution licensee in net metering system and joint meter readings in gross metering system shall form the basis of commercial settlement.
- 7.6 The technical standards for meters shall be as per (**Annexure-III**) and shall comply with the standards specified by Central Electricity Authority (Installation and Operation of Meters) Regulations, 2006 as amended from time to time.
- 7.7 The meters installed for grid connected rooftop solar power plants with capacity above 250 kWp and other Renewable Energy Plant with capacity above 250 kW shall have the communication port for exchanging real time information with Distribution Licensee.

## **8. Energy Accounting, tariff and Settlement:**

- 8.1 The energy accounting, tariff and settlement of the renewable energy system shall be as per the connection agreement or power purchase agreement executed between the developer and the distribution licensee provided that the power purchase agreement shall be vetted by the Commission. The accounting of the electricity generated, consumed and injected by the rooftop solar system under these regulations shall become effective from the date of connectivity of such system with the network of distribution licensee.

8.2 The procedure for billing and energy accounting in respect of net metering rooftop solar power plant shall be as under:-

- (1) For each billing cycle the Seller shall receive an energy account statement showing quantum of electricity injected by the eligible consumer in the billing period, electricity supplied by the distribution licensee in the billing period, net billed electricity for payment by the consumer for that billing cycle and net carried over electricity to then next billing period separately.
- (2) In case the electricity injected exceeds the electricity consumed from licensee's supply system during the billing cycle such excess injected electricity shall be carried forward to the next billing cycle as electricity credit and shown as electricity exported by the consumer for adjustment against the electricity consumed in subsequent billing periods within the settlement period. In such a case, the distribution licensee shall issue an invoice containing all these details.
- (3) In case the electricity supplied by the distribution licensee during any billing period exceeds the electricity injected by the eligible consumer, the distribution licensee shall raise a bill for net electricity consumption as per applicable tariff of that category after taking into account any electricity credit balance from previous billing period.
- (4) In case the eligible Seller is under the ambit of TOD tariff, the electricity consumption in anytime block i.e. peak hours, off peak hours etc. shall be first compensated with the electricity injected in the same time block. Any excess injection over and above the consumption in any other time block in a billing cycle shall be accounted as if the excess injection occurred during non-peak hours.
- (5) The surplus energy measured in kWh/kVAh shall be utilized to offset the consumption measured in kWh/kVAh and may not be utilized to compensate any other fee and charges imposed by the licensee as per the orders of the Commission. A normative power factor of 0.9 shall be considered for conversion of kWh to kVAh, wherever applicable.
- (6) The monthly fixed charge and other fees and charges as per applicable Tariff Order of the Commission shall be leviable on contract demand or contracted load of the consumer for each billing cycle. The monthly fixed charge shall not be leviable on the capacity of grid connected renewable energy system of the eligible consumer.
- (7) The distribution licensee shall also take the reading of solar meter for recording total solar power generated by solar energy system of eligible Seller.

- (8) The distribution licensee in addition to consumer tariff shall be eligible to raise invoice/bills for any other charges as allowed by the Commission.
- (9) In case of any dispute in billing, the consumer can approach the licensee, who shall deal the complaint under provisions of Regulations 6.24 to 6.27 of the JERC for Manipur and Mizoram (Electricity Supply Code) Regulations, 2013 with subsequent amendments thereof. In case the Seller feels aggrieved by the licensee's disposal of the complaint, the Seller can approach Consumer Grievances Redressal Forum and Electricity Ombudsman in accordance with JERC for Manipur and Mizoram (Consumer Grievance Redressal) Regulations, 2010, as amended from time to time.
- (10) The Seller shall be paid for net energy credits which remain unadjusted at the end of the settlement period at the levelled tariff (feed-in-tariff) determined and fixed by the Commission from time to time depending on prevailing circumstances. Provided also that at the beginning of each settlement period, cumulative carried over solar electricity injected shall be reset to zero.
- (11) All the rules & regulations applicable to the consumers of the distribution licensee for the applicable category shall also be applicable to the eligible consumer who uses the rooftop solar energy system.

### **8.3 BILLING AND PAYMENT:**

- (1) MSPDCL shall issue monthly electricity bill for the net energy on the scheduled date of meter reading by the representatives of MSPDCL / consumer / Generator (Seller).
- (2) \*In case, the exported energy is more than the imported energy, MSPDCL shall pay for the net energy exported as per Clause no. 6.2 (a) of this agreement within the \*\*settlement period duly adjusting the fixed charges and electricity duty if any.
- (3) In case, the exported energy is less than the imported energy, the seller shall pay MSPDCL for the net energy imported as per the prevailing retail supply tariff determined by the Commission from time to time.
- (4) MSPDCL shall pay interest at the same rates as is being levied on the consumers for late payment charges in case of any delay beyond 30 (thirty) days period from the date of settlement for payment of energy credits.



Explanation: Net energy means the difference of meter readings of energy injected by the SRTPV system into the grid (export) and the energy drawn from the grid for use by the seller (import) recorded in the bi-directional meter.

Note \*”The clause No.8.3 sub cl. No. (2) May be amended subject to the approval of Govt. of Manipur from time to time.”

\*\*”Settlement period” means the period beginning from first of April in an English calendar year and ending with the thirty first of the March of next year.

## **9. Term for Termination of the Agreement**

- 9.1 This agreement shall be in force for a period of 25yrs from the date of commissioning of the SRTPV system unless terminated otherwise as provided here under.
- 9.1(a) This agreement shall be valid for 25yrs subject to the condition that Date of Commissioning / injection to the Grid of this SRTPV must be done within 6months from the date of signing of this PPA unless this agreement shall be automatically considered as invalid.
- 9.2 If the MSPDCL commits any breach of the terms of the Agreement, the Seller shall serve a written notice specifying the breach and calling upon the MSPDCL to remedy/ rectify the same within 30 (thirty) days or at such other period and at the expiry of 30 (Thirty) days or such other period from the delivery of the notice, Seller may terminate the agreement by delivering the termination notice, if the MSPDCL fails to remedy/ rectify the same.
- 9.3 If the Seller commits any breach of the terms of the Agreement, MSPDCL shall serve a written notice specifying the breach and calling upon the seller to remedy/ rectify the same within 30 (thirty) days or at such other period and at the expiry of 30 (Thirty) days or such other period from the delivery of the notice, MSPDCL may terminate the agreement by delivering the termination notice, if the seller fails to remedy/ rectify the same.
- 9.4 Upon termination of this Agreement, the seller shall cease to supply power to the distribution system and any injection of power shall not be paid for by the MSPDCL.

**10. Dispute Resolution:**

All the disputes between the parties arising out of or in connection with this agreement shall be first tried to be settled through mutual negotiation.

The parties shall resolve the dispute in good faith and in equitable manner.

In case of failure to resolve the dispute, either of the parties may approach the appropriate Forum of law.

IN WITNESS WHEREOF, the Seller & the MSPDCL have entered into this Agreement in three originals executed on the date and year first set forth above.

WITNESS

For and on behalf of SELER

1.

2.

WITNESS

For and on behalf of MANIREDA

1.

2.

WITNESS

For and on behalf of MSPDCL

1.

2.

**Schematic Arrangement for Interconnection of Rooftop & Small PV Solar Plant with the Distribution licensee's/Grid**

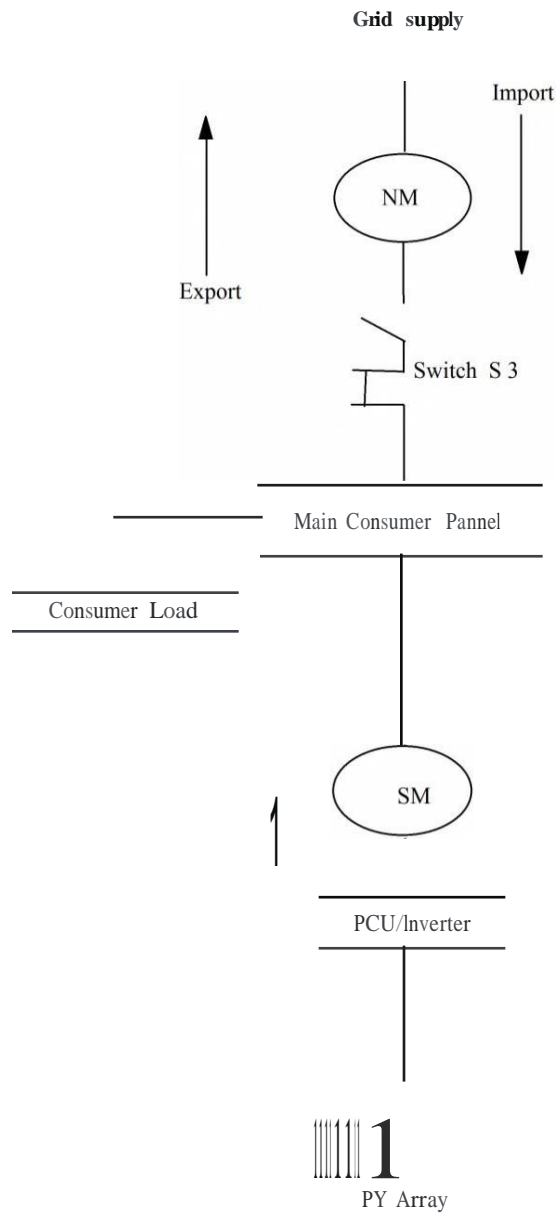

Normal Solar Generation shall be connected with Grid. When Grid fails, Inverter controlled Switch S3 opens, on restoration of Grid S3 closes.

Abbreviations:-

NM = Net Meter, SM = Solar Meter, PCU = Power Conditioning Unit.

Net Metering configuration options

(1) Two metering configuration without storage

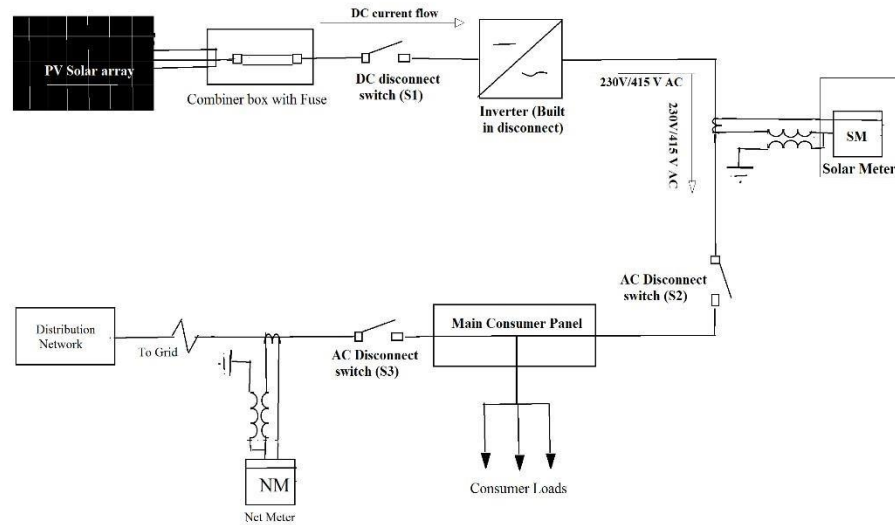

(2) Two meter configuration with storage

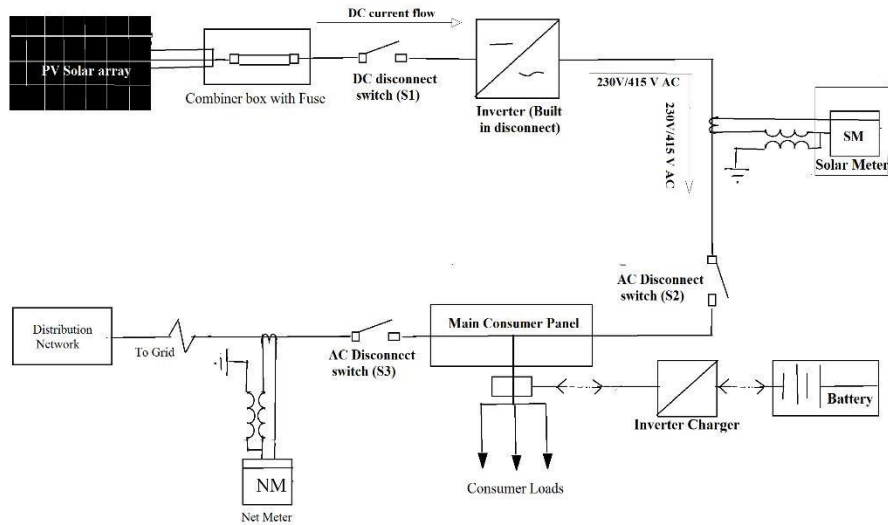

Key observations:-

- Two meter configuration is most optimal configuration –allows discrete & separate measurement of both solar and utility power.
- The presence of the solar meter allows use of generation based incentives like REC / GBI, etc.
- Key issues- 1) Acceptability of solar meter as a commercial meter; 2) Placement of of the solar meter - should it be next to the main utility meter or next to the solar inverter; 3) Need for solar check meter? 4) Need for an easily accessible external AC disconnect switch.

**Specification for meters for net/gross metering****(a) Meter for Solar Generation Measurements:****Solar Meter Major Technical Parameters**

Sl. No.	Technical Parameters	Connectivity at 415V & below voltage level			Connectivity at above 415 V voltage level
		Whole current meters	CT operated	CT-PT Operated	
1	Applicability	Solar plant capacity upto 4 kW	Solar plant capacity above 4 kW and upto 15 kW	Solar Plant Capacity above 15 kW and upto 100 kW	HT/EHV supply
2	Number of phases and wires	Single Phase, 2 Wire	Three Phase, 4 Wire	Three Phase, 4 Wire	Three Phase, 4 Wire
3	Measurand(s)	kWh	kWh	kWh, kVAh, kVA, PF	kWh, kVAh, kVA, PF, Max. demand
4	Standard Voltage and frequency	240 V,	3X240V (P-N), 415 V (P-P) 50±5%	3X240V (P-N), 415V (P-P) 50±5%	3X63.5 V(P-N), 110 V (P-P) 50±5%
5	Current Rating	10-60	10-60	1 Amp	1 Amp
6	Accuracy class	1.0	1.0	0.5S	0.5S
7	Indian Standard or IEC to which conforming	IS 13779-1999	IS13779-1999	IS 14697, IS 13779	IS 14697, IS 13779
8	Import-export feature	Forward import	Forward import	Forward import	Forward import
9	Communication Port/ Protocol	Optical/ DLMS	Optical,RS-232/ DLMS	Optical,RS-232/ DLMS	Optical,RS-232/ DLMS

**(b) Meter for Net-Metering Measurements:  
Net-Meter Major Technical Parameters**

Sl. No.	Technical Parameters	Connectivity at 415V & below voltage level			Connectivity at above 415 V voltage level
		Whole current meters	CT operated	CT-PT Operated	
1	Applicability	Upto 5 kW connected load	Above 5 kW and upto 15 kW connected load	Above 15 kW and upto 100 kW contract demand	HT/EHV supply
2	Number of phases and wires	Single Phase, 2 Wire	Three Phase, 4 Wire	Three Phase, 4 Wire	Three Phase, 4 Wire
3	Measurand(s)	kWh	kWh	kWh, kVAh, kVA, PF	kWh, kVAh, kVA, PF, Max. demand
4	Standard Voltage and frequency	240 V, 50±5%	3X240V (P-N), 415 V (P-P) 50±5%	3X240V (P-N), 415V (P-P) 50±5%	3X63.5 V(P-N), 110 V (P-P) 50±5%
5	Current Rating	10-60	10-60	1 Amp	1 Amp
6	Accuracy class	1.0	1.0	0.5S	0.5S
7	Indian Standard or IEC to which conforming	IS 13779-1999	IS13779-1999	IS 14697, IS 13779	IS 14697, IS 13779
8	Import-export feature	Import & Export	Import & Export	Import & Export	Import & Export
9	Communication Port/ Protocol	Optical/ DLMS	Optical,RS-232/ DLMS	Optical,RS-232/ DLMS	Optical,RS-232/ DLMS